



Electrolux
PROFESSIONAL

**High Productivity Cooking
Touchline tilting pressure braising
pan, gas (61,362BTU), 24 gal (90 lt)**

ITEM # _____
 MODEL # _____
 NAME # _____
 SIS # _____
 AIA # _____



High Productivity Cooking
Touchline tilting pressure braising pan, gas (61,362BTU), 24 gal (90 lt)



587027 (PUET09GCWU) Touchline tilting pressure braising pan, gas (61,362BTU), 24gal capacity (90lt) - 120V/1p/60Hz

Short Form Specification

Item No. _____

AISI 304 stainless steel construction. GN compliant pan size; 0.7" (18mm) thick pan bottom 0.6" (15mm) mild steel and 0.1"(3mm) AISI 316 stainless steel. Insulated and counterbalanced lid. Motorized tilting with variable speed control. Pan can be tilted beyond 90° to completely empty the food. Robust multiple burners with electronic ignition and monitoring. Safety thermostat protects the pan from overheating. A precise, electronic control of pan bottom temperature ensures fast reaction and exact adherence to pre-selected cooking temperatures between 122°F and 482°F (50°C and 250°C). Automatic steam elimination at the end of the cooking cycle. It can be used for poaching or steaming (with the lid open); simmering and boiling (with open or closed lid). TOUCH control panel. SOFT function. PRESSURE function. IPX6 water resistant. Configuration: Free-standing or Against a wall. Installation options (not included): floor mounted on 8" (200mm) high feet or a plinth which can be either steel or masonry construction.

Main Features

- Multifunctional cooking appliance used for roasting, pot-roasting, braising, simmering, boiling, pressure cooking and steaming.
- Pan size is GN compliant.
- Temperature sensors provides efficient temperature control: the power is supplied as and when required to keep the set temperature value without exceeding it.
- Easy to clean cooking surface due to large-radius edges and corners.
- Cooking with a working pressure of 6.5psi (0.45 bar) reduces cooking times.
- Optimum heat distribution in the food provides best cooking results in terms of taste, color and consistency and in terms of vitamin preserving.
- Safety mechanism prevents lid from opening, even in case of voluntary attempt, when cooking under pressure.
- Overnight cooking: saving electricity and time.
- Safety valve on the lid avoids overpressure in the food compartment.
- IPX6 water resistant.
- Motorized, variable pan tilting with "SOFT STOP". Tilting and pouring speeds can be precisely adjusted. Pan can be tilted over 90° to facilitate pouring and cleaning operations.
- "Pressure function": once the pressure lid is locked, the system automatically regulates itself.
- Built in temperature sensor to precisely control the cooking process.
- No overshooting of cooking temperatures, fast reaction.
- USB connection to easily update the software, upload/download recipes and download HACCP data.

Construction

- External panelling and internal frame made of 1.4301 (AISI 304) stainless steel.
- Multipurpose non-stick cooking surface in 0.75" (18 mm) thick compound: 0.1" (3 mm) shot-blasted 1.4404 (AISI 316L) stainless steel surface, seamlessly welded to the mild steel bottom.
- Double-lined insulated lid in 1.4301 (AISI 304) stainless steel mounted on the cross beam of the unit, counterbalanced by a hinge that remains open in all positions.
- Gas appliance has robust multiple burners with electronic ignition and monitoring for a safer operation. Operation with natural gas and LPG (on request).
- Water mixing tap is available as optional accessory to make water filling and pan cleaning easier.
- Pressure lid fitted with a proven fast-acting lock which is simple and safe in operation.
- Heatproof handle with non-slip surface.
- Front-mounted inclined led "TOUCH" control panel with recessed deep drawn casing, features self-explanatory display functions which guide operator throughout the cooking process: simultaneous display of actual and set temperature as well as set cooking time and remaining

APPROVAL: _____



cooking time; real time clock; "SOFT" control for gentle heating up for delicate food; 9 power simmering levels from gentle to heavy boiling; timer for deferred start; error display for quick trouble-shooting.

- Minimised presence of narrow gaps for easier cleaning of the sides to meet the highest hygiene standards.
- "Boiling" or "Braising" mode functions.
- Can be prearranged for energy optimisation or external surveillance systems (optional).
- 98% recyclable by weight; packaging material free of toxic substances.
- Model equipped with TDO valve available as special execution (S/code request)
- [NOT TRANSLATED]
- [NOT TRANSLATED]
- [NOT TRANSLATED]

User Interface & Data Management

- Connectivity ready for real time access to connected appliances from remote and data monitoring (requires optional accessory - contact the Company for more details).

Sustainability



- High-quality thermal insulation of the pan saves energy and keeps operating ambient temperature low.

Optional Accessories

- | | | |
|--|------------|--------------------------|
| • Suspension frame for Pressurized Tilting Braising Pans - 2 needed for 24 gallon units (587021, 587027) - 3 needed for 45 gallon units (587025, 587028) | PNC 910191 | <input type="checkbox"/> |
| • Base plate, for pressure braising pans and non-pressure braising pans, half size - 2 needed for 24 gallon units (587031, 587037, 587021, 587027) - 3 needed for 45 gallon units (587035, 587039, 587025, 587028) | PNC 910201 | <input type="checkbox"/> |
| • Perforated container with handles, height 4" (102mm) | PNC 910211 | <input type="checkbox"/> |
| • Perforated container with handles, height 6" (152mm) | PNC 910212 | <input type="checkbox"/> |
| • Perforated container with handles, height 8" (203mm) | PNC 911673 | <input type="checkbox"/> |
| • Left cover plate and mixing faucet for kettle (587040), and all braising pans (587037, 587039, 587031, 587035, 587027, 587028, 587021, and 587025) | PNC 911819 | <input type="checkbox"/> |
| • Spray gun for tilting units, height 27-1/2" (698.5mm) - factory fitted | PNC 912776 | <input type="checkbox"/> |
| • SCRAPER WITHOUT HANDLE (PFEX/PUEX) | PNC 913431 | <input type="checkbox"/> |
| • - NOT TRANSLATED - | PNC 913432 | <input type="checkbox"/> |
| • 4 flanged feet, 2", for prothermetic units (kettles, braising pans & pressure braising pans) | PNC 913438 | <input type="checkbox"/> |
| • - NOT TRANSLATED - | PNC 913575 | <input type="checkbox"/> |
| • - NOT TRANSLATED - | PNC 913577 | <input type="checkbox"/> |
| • Spray gun kit for free-standing ProThermetic Tilting units H=700 - US - Field Mounted | PNC 913579 | <input type="checkbox"/> |

High Productivity Cooking Touchline tilting pressure braising pan, gas (61,362BTU), 24 gal (90 lt)

Front

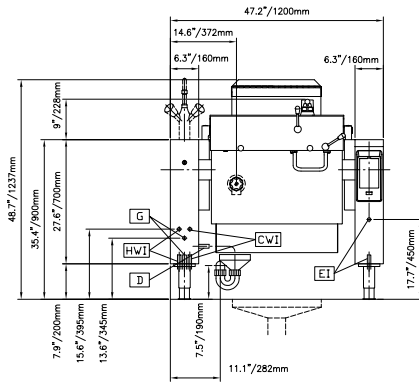

Side

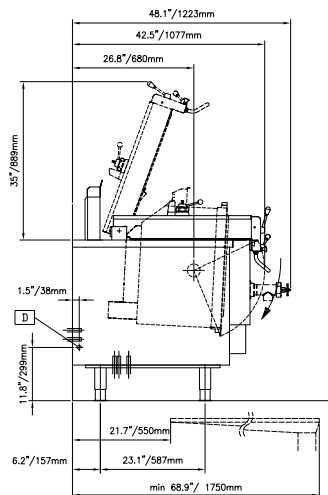

CWII = Cold Water inlet G = Gas connection

D = Drain

EI = Electrical connection

Top

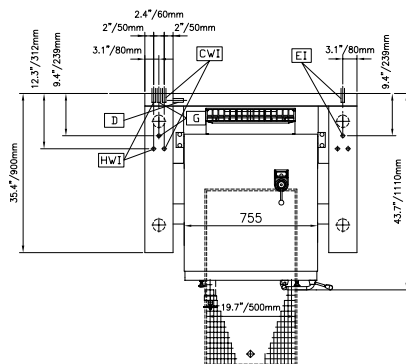

Electric

Supply voltage: 120 V/1 ph/60 Hz
 Total Watts: 0.25 kW

Gas

Gas Power: 61416 Btu/hr (18 kW)
 Gas Type Option: Propane
 Gas Inlet: 3/4"

Water:

Pressure: 29-87 psi (2-6 bar)
 Drain line size: 1/2"
 Incoming Cold/hot Water line size: 1/2"

Installation:

Type of installation: FS on concrete base; FS on feet; On base; Standing against wall

Key Information:

Working Temperature MIN: 122 °F (50 °C)
 Working Temperature MAX: 482 °F (250 °C)
 External dimensions, Width: 47 1/4" (1200 mm)
 External dimensions, Depth: 35 7/16" (900 mm)
 External dimensions, Height: 27 9/16" (700 mm)
 Net weight: 529 lbs (240 kg)
 Shipping width: 52" (1320 mm)
 Shipping depth: 49 5/8" (1260 mm)
 Shipping height: 58 1/4" (1480 mm)
 Shipping weight: 963 lbs (437 kg)
 Shipping volume: 86.92 ft³ (2.46 m³)
 Configuration: Rectangular; Tilting
 Heating type: Direct
 Tilting mechanism: Automatic